

PK-44002-Performance

Technische Daten

Endless slewing mechanism

The standard endless slewing mechanism provides an unrestricted action radius. As a result the crane operates much more quickly and cost-efficiently.



Functional Design

- Cover for the control valve area
- Covering for the hoses behind the crane column
- Outrigger system with internally routed hydraulic hoses



Load-holding valves

They prevent the crane arm from dropping and are fitted as standard onto the slewing mechanism, lifting and boom extension cylinders. The valves are positioned in such a way that they are protected from being damaged.



AOS

The Active Oscillation Suppression system, which is available exclusively from PALFINGER, compensates for jolts and sharp stress cycles caused by crane operation. Because oscillations are eradicated, the crane can work with pin-point accuracy, much more quickly and therefore more cost-efficiently.

Advanced Package

- Oil cooler mounted
- Electronic HPLS
- Capacity display on control console
- PALFINGER radio control
- PALTRONIC 50
- Functional Design
- Load Sensing operation



Control valve

In combination with the PALFINGER radio control system the load sensing proportional valve enables the crane to be adjusted very sensitively.

Johann Strauss GmbH
Museumstraße 11
4643 Pettenbach

Tel: +43 7586 6005 0
E-Mail: office@strauss-log.at
web: www.strauss-log.at

STRAUSS

TRANSPORT / KRAN / CONTAINER / LAGER

PK-44002-Performance

Technische Daten



Hose equipment for accessories

With this option you can provide the oil supply to accessories. The hoses are routed in compact troughs and plastic link chains. They are therefore optimally protected.

Return oil utilisation

The high speed of the extension system is impressive. It results from return oil utilisation, which is installed as standard, and the generously dimensioned hydraulic lines. This makes for increased efficiency in any type of working!

Internally routed oil ducts

The internally routed oil ducts permit a compact design for the extension system and ensure perfect protection from damage.

Outrigger system

The 7.4 m outrigger system is fitted as standard with support cylinders that can be hydraulically swivelled up 180° and ensures optimal stability. The control valves for crane and additional supports are mounted as standard equipment on the base frame. The switch-over between crane and outrigger control takes place electrically. Bubble level and hour counter are mounted in the support control valve console.

POWER LINK PLUS

This hinged arm specially developed by PALFINGER can be angled upwards and exhibits outstanding movement geometry. Even in unfavourable site conditions heavy crane work can be carried out without any problems.

KTL – the cathodic dip painting

The shot-blasted crane parts are covered in zinc phosphate in an immersion process and coated electrostatically. The subsequent two-component top coating of paint provides a surface protection which in the past was usually only found in the automotive industry.



Johann Strauss GmbH
Museumstraße 11
4643 Pettenbach

Tel: +43 7586 6005 0
E-Mail: office@strauss-log.at
web: www.strauss-log.at

STRAUSS

TRANSPORT / KRAN / CONTAINER / LAGER

PK-44002-Performance

Technische Daten

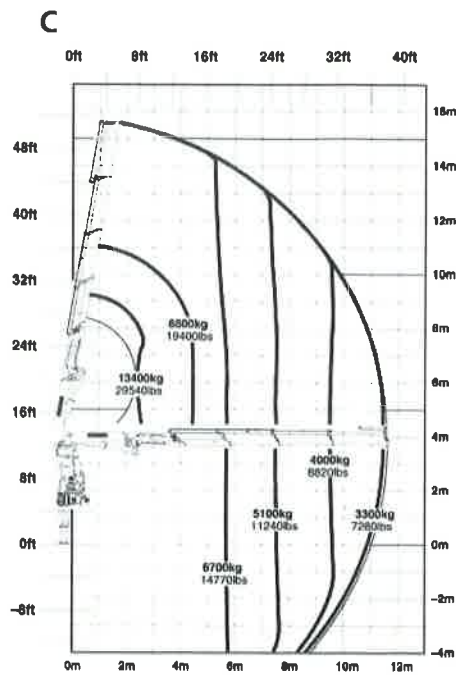
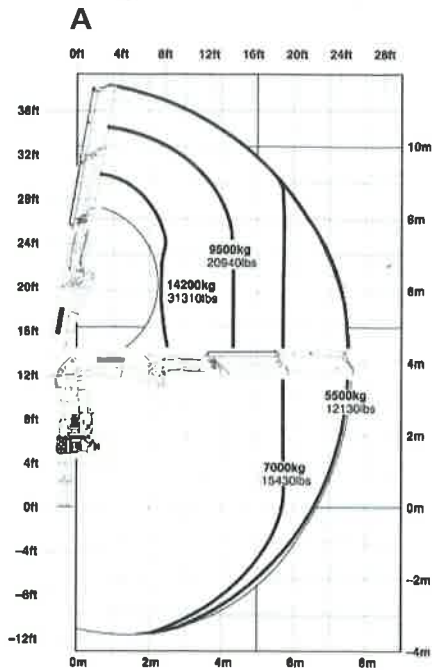

Johann Strauss GmbH
Museumstraße 11
4643 Pettenbach

Tel: +43 7586 6005 0
E-Mail: office@strauss-log.at
web: www.strauss-log.at

STRAUSS

TRANSPORT / KRAN / CONTAINER / LAGER

PK-44002-Performance

Technische Daten

D

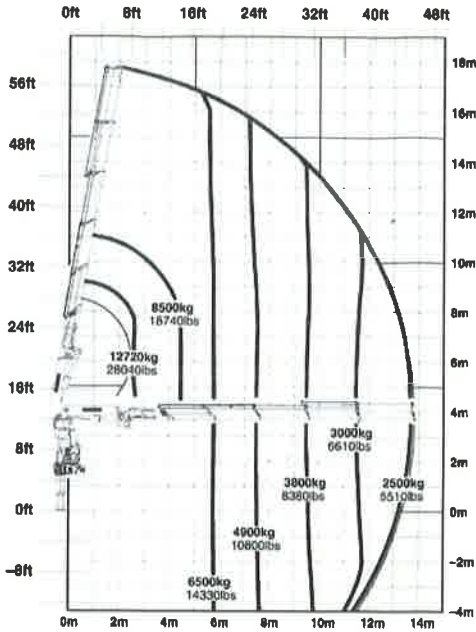

E

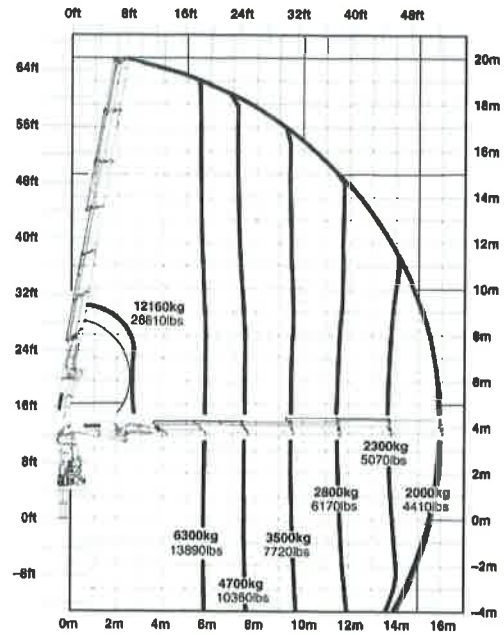

D PJ125E

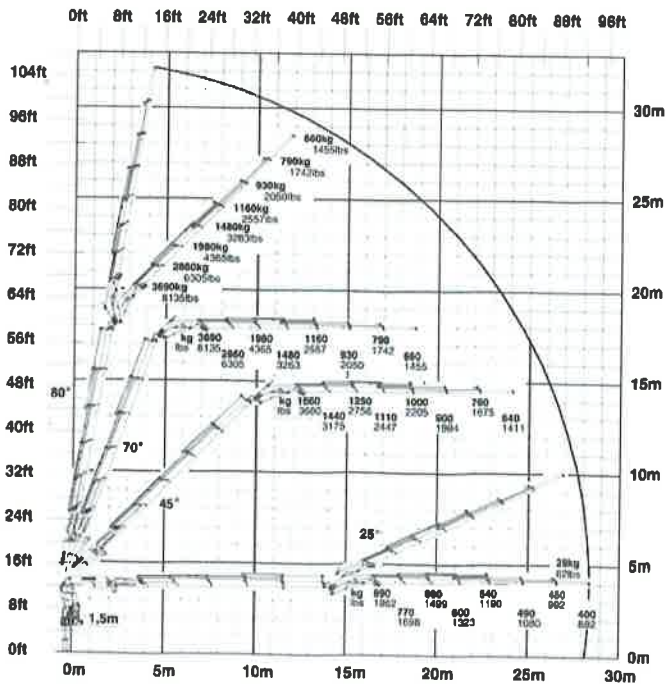

E PJ080C

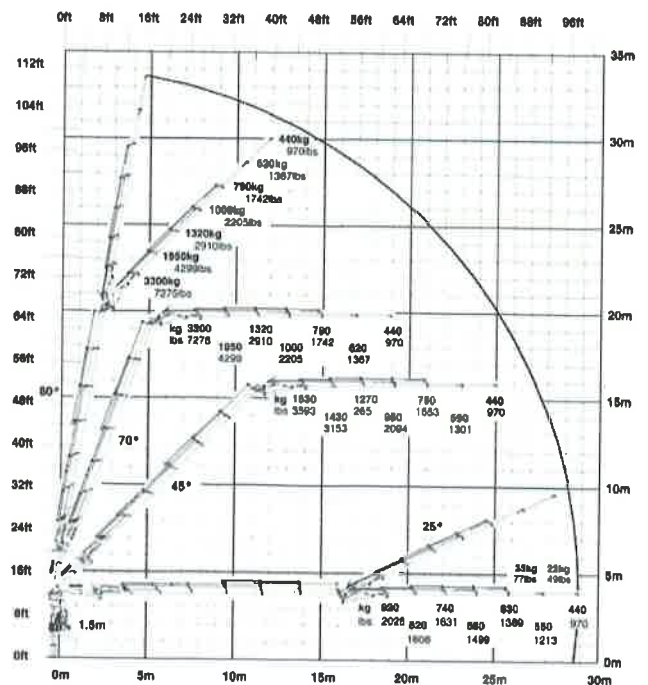

Johann Strauss GmbH
Museumstraße 11
4643 Pettenbach

Tel: +43 7586 6005 0
E-Mail: office@strauss-log.at
web: www.strauss-log.at



PK-44002-Performance

Technische Daten

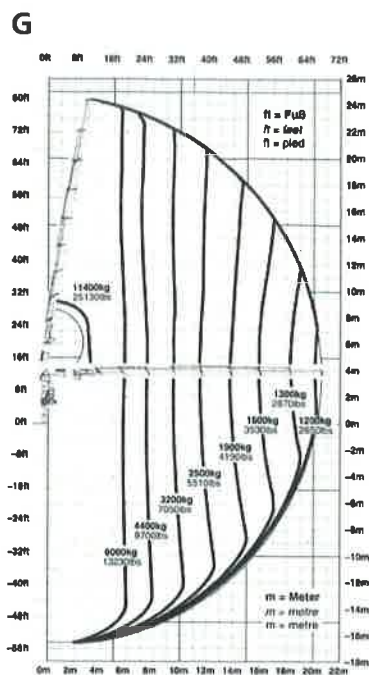
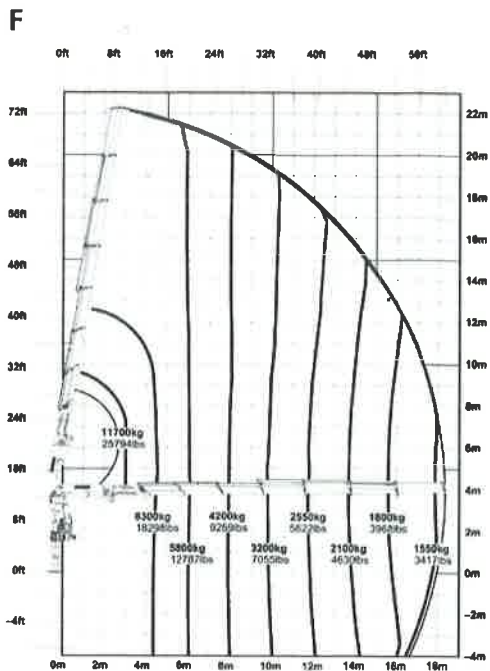

F PJ060B

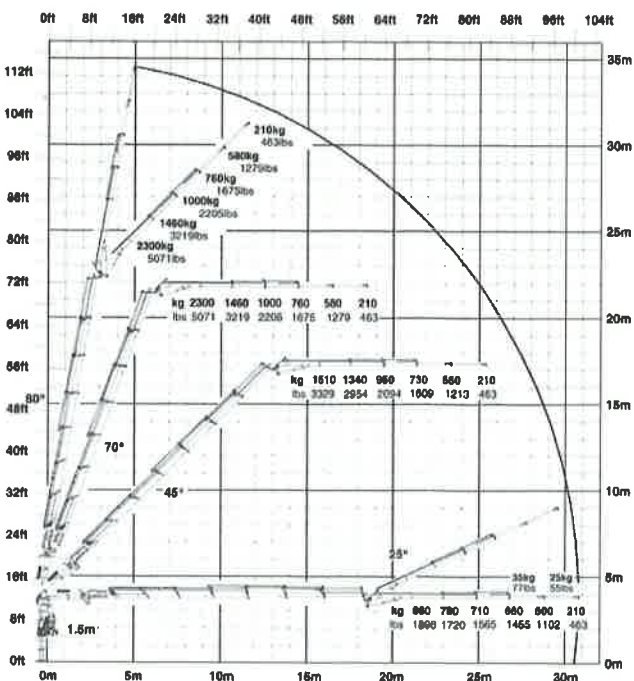

Johann Strauss GmbH
Museumstraße 11
4643 Pettenbach

Tel: +43 7586 6005 0
E-Mail: offic@strauss-log.at
web: www.strauss-log.at



PK-44002-Performance

Technische Daten

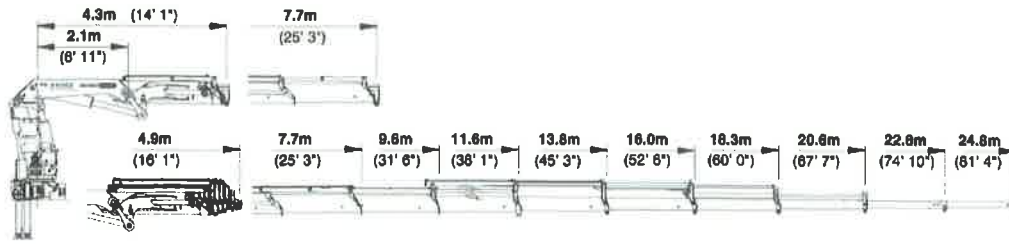

PK 44002D PJ125E



PK 44002E PJ080C



PK 44002F PJ080B

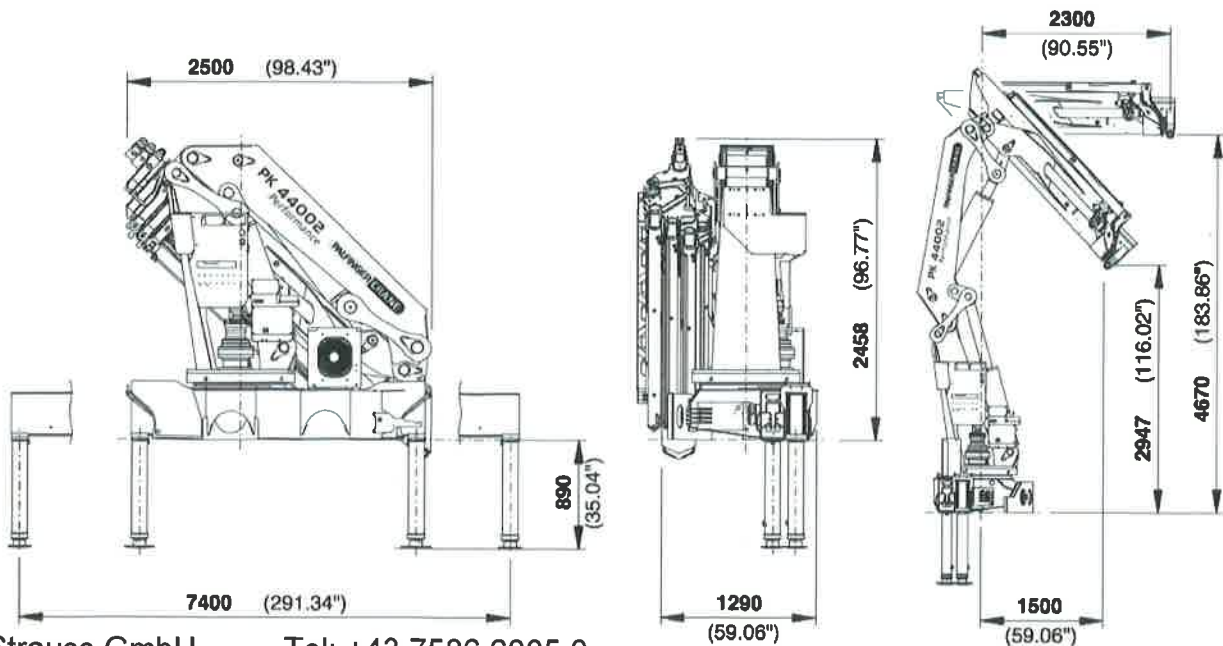

Johann Strauss GmbH
Museumstraße 11
4643 Pettenbach

Tel: +43 7586 6005 0
E-Mail: office@strauss-log.at
web: www.strauss-log.at

STRAUSS

TRANSPORT / KRAN / CONTAINER / LAGER

PK-44002-Performance

Technische Daten

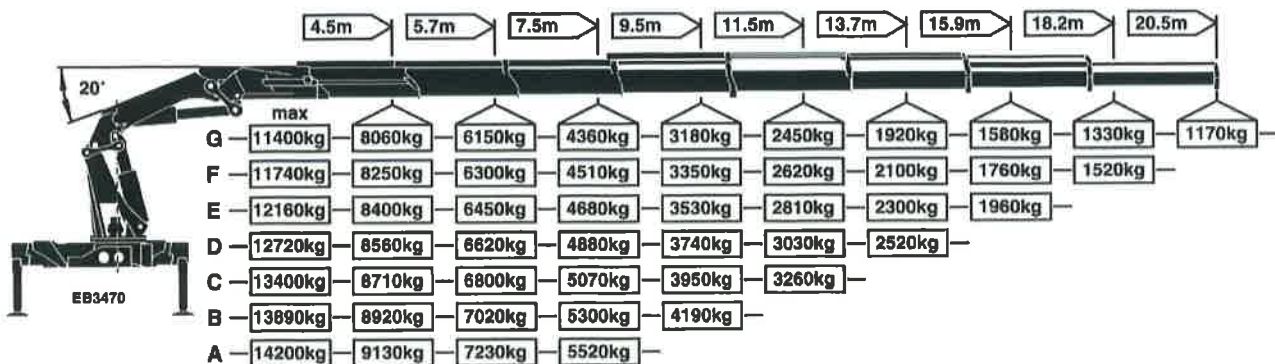

The outreaches stated are with a boom angle of 20° and are therefore not the maximum.

PK 44002 Performance		
Technical Specifications (EN 12999 H1-B3)		
Max. lifting moment	42.5 mt/416.9 kNm	307380 ft.lbs
Max. lifting capacity	14500 kg/142.2 kN	31970 lbs
Max. hydraulic outreach	20.6 m	67' 7"
Max. manual outreach	24.8 m	81' 4"
Max. outreach (with fly-jib)	30.8 m	101' 1"
Slewing angle	endless	

PK 44002 Performance		
Standard crane		
Slewing torque	4.5 mt/44.1 kNm	32510 ft.lbs
Outreach	7.7 m	25' 3"
Stabilizer spread standard	7.4 m	24' 3"
Fitting space required	min. 1.29 m / 4' 3"	max. 1.46 m / 4' 9"
Width folded	2.5 m	8' 3"
Max. operating pressure	330 bar	4785 psi
Recommended pump capacity with RC- and LS-system	from 80 l/min	17.6 imp.gal./min 21.1 US gal./min
	to 100 l/min	22.0 imp.gal./min 26.4 US gal./min
Dead weight standard crane	4095 kg	9030 lbs

Applications shown in the leaflet do not always correspond to the standard specifications. Design and specification are subject to change without prior notice.

Johann Strauss GmbH
Museumstraße 11
4643 Pettenbach

Tel: +43 7586 6005 0
E-Mail: office@strauss-log.at
web: www.strauss-log.at

STRAUSS

TRANSPORT / KRAN / CONTAINER / LAGER